

Investigating the Effect of Changing the Span Length and the Number of Floors on the Seismic Parameters of the Confined Masonry Wall

Samaneh Khaksefidi*, HosseinAli Rahdar

Department of Civil Engineering, University of Zabol, Zabol, Iran

Corresponding author's e-mail: *khaksefidi@uoz.ac.ir*

Article Information

Received: 05 January 2024
Revised: 31 January 2024
Accepted: 01 February 2024
Published online: 19 February 2025

Keywords

Masonry structures
Seismic vulnerability
Damage index
Brick walls

Abstract

Non-reinforced brick structures around the world, especially in Iran and in small towns, have a major part of building types, and usually, these types of structures are major weaknesses in the earthquake. So, the vulnerability of these structures under earthquake, has particular features. Also, most of the structures that have historical significance are built using masonry. Hence, analyzing the behavior of these structures, the breaks, and assess, the risk factors on the mechanisms have a significant influence on the selection of appropriate methods of rehabilitation and retrofitting masonry buildings. Studies on masonry buildings after earthquake show that fragility of materials and non-continuity of these buildings are a main factor of destruction at the time of earthquake. There are similar damages occurred by earthquake on these structures regarding to the kind of construction of these structures. Nowadays, damage index is used as a tool for accurate evaluation of structure, and decision-making to determine the amount of damages to structures, the advantage of the damage indexes is identifying structure condition, besides identifying the amount of damages, and also is used as a criterion for decision-making. In this research, we are investigating mechanisms broke and vulnerability brick buildings. The comparison of data shows that by reducing the maximum acceleration of earthquakes for different seismic zones, the damage to the walls decreases so that for the medium and low seismic zones, none of the walls reach the limit of irreparable damage. Moreover, it is added to the number of walls that have minor damage.

© 2025 University of Zabol. All rights reserved.

1. Introduction

Before use, new building materials, such as concrete, steel, and masonry, have been promoted as the main materials for buildings. However, at the present time, this type of construction is used due to ease and economics. By examining the damage in the past earthquakes on these structures, we can understand that, most structural materials

have seen considerable damage. Strength and low ductility, lack of structural integrity, structural weight, and decrease resistance under lateral loads, are among the reasons for the broke of the brick structure. Due to the large number of buildings, residential areas in our country are built using masonry materials and cements that in the context of the brick structure. In our country, there are no specific instructions in the design and construction of this type of structure, presentation, and content, which has the applications of engineering in the design, study of seismic vulnerability, and retrofit methods, which are useful. Therefore, the vulnerability of these structures under earthquake has particular. In this paper, broken mechanisms of brick structures are examined.

2. Materials and Methods

2.1 Masonry materials

Compressive stress-strain diagram of masonry brick constructional material is illustrated in Figure 4. This diagram is considered as a parabolic function till the maximum stress of f_m' , then with the increase of strain, the value of stress is decreasing linearly and after that is a fixed value. The assumed model for coverage of the strength of the brick panel is illustrated in Figure 5; this coverage model shows compressive behavior.

Cyclic force-displacement diagram for compressive situation is shown in Figure 6 [1-3]. Taking a confined brick wall in Figure 7 into consideration, the maximum lateral force V_m and the relevant displacement U_m are as follows:

$$V_m \leq A_d f_m' \cos \theta \leq \frac{vtl'}{(1 - 0.45 \tan \theta') \cos \theta} \leq \frac{0.83(Mpa) t l'}{\cos \theta} \quad (1)$$

$$U_m = \frac{\varepsilon_m' L_d}{\cos \theta} \quad (2)$$

where t is the thickness of wall, f_m' is prism strength of masonry materials; ε_m' is relevant strain, V is basic shear resistance or tenacity of masonry, A_d , L_d are area and equivalent length of diagonal member, respectively.

$$A_d = (1 - \alpha_c) \alpha_c t h' \frac{\sigma_c}{f_c} + \alpha_b t l' \frac{\tau_b}{f_c} \leq \frac{0.5 h' f_a}{\cos \theta} \quad (3)$$

$$L_d = \sqrt{(1 + \alpha_c)^2 h'^2 + L^2} \quad (4)$$

The values of α_c , α_b , τ_b , f_a , f_c are related to geometry and the characteristics of confined material and wall (infill frame). Allowable stress f_a is resulted from the following equations:

$$f_c = 0.6 \times \phi \times f_m' \quad f_a = f_c \left[1 - \left(\frac{L_{ef}}{40 t} \right) \right], \phi = 0.65 \quad (5)$$

Uniform contact stresses at the time of fracture at the joint of vertical ties with wall σ_{c0} and horizontal ties with brick wall σ_{b0} based on Tereska hexagonal gauges yielding is as follows:

$$\sigma_{co} = \frac{f_c}{\sqrt{1 + 3\mu_f^2 r^4}} \quad \sigma_{b0} = \frac{f_c}{\sqrt{1 + 3\mu_f^2}} \quad (6)$$

where r is height of wall to length of wall ratio and μ_f is friction factor of wall with ties. In one-dimensional force-displacement diagram, the maximum force of V_m and the relevant displacement U_m , initial stiffness K_0 , and stiffness of ultra-yielding to initial stiffness ratio α are considered. The initial stiffness K_0 can be estimated as follows:

$$k_0 = \frac{V_y}{U_y} \quad (7)$$

Lateral yielding force and the relevant displacement in brick panel are as follows [4]:

$$V_y = \frac{V_m - \alpha K_0 U_m}{1 - \alpha} \quad (8)$$

$$U_y = \frac{V_m - \alpha K_0 U_m}{K_0 (1 - \alpha)} \quad (9)$$

For α , the value 0.1 is suggested.

Specification values of masonry material used in the model are as follows:

- prism strength of masonry materials: $f_m = 0.00623$ (KN/mm²)
- Cracking modulus of masonry materials: $f_{mcr} = 0.005 f_m = 0.000315$ (KN/mm²)
- Corresponding strain prismatic strength: $E_{psm} = 0.002$
- Basic shear strength of layers of attached masonry: $V_m = 0.00031$ (KN/mm²)
- The coefficient of friction between the wall and the confine: $C_{fm} = 0.3$

2.2 Types of relative risks in seismicity of Iran

Based on the Seismicity history of different regions and also according to survey data from various regions, seismicity parameters have been specified for each active fault or source regional seismic creation. By these given data and the values of maximum acceleration component, Iran has been segmenting into the different seismicity zone that according to the map of seismicity zoning of Iran, existing under the 2800 standard has four seismicity zones [1]:

1. Zone with very high relative risk
2. Zone with high relative risk
3. Zone with a moderate relative risk
4. Zone with low relative risk

In order to precisely examine structures under a variety of earthquake effect, the records of earthquakes should be used in the intended condition of site.

Accelerograms that are selected for the design in terms of frequency content, spectral response, and durability (duration) strong ground movements should be similar to the movements of the earth intense which its event is

possible in studied region. In the selection and expansion time histories, paying attention to the characteristics geologic of the site and site location is obligatory. Accelerograms that have response spectra coordinated with design spectrum for the site, are called accelerogram consistent with design spectrum, and are used for time history analysis of intended structure. These accelerograms are provided by the following methods:

- 1- Using the recorded accelerograms that is proportional to the condition of site and modifying them.
- 2- Using the design spectrum and manufacture of artificial accelerograms compatible with the standard methods for producing these accelerograms.

Therefore, in order to study and needed analyzes in different zones of relative risk of seismicity of Iran, intended accelerograms that are used for different zones of relative risk should be corrected. To remedy this, accelerogram records must be multiplied in a correction coefficient by the correction coefficient that is obtained as follows:

$$\text{Acceleration correction coefficient} = A/A_{\max} \quad (10)$$

A= Acceleration of basis for the desired relative risk

A_{max}= Maximum Acceleration for used accelerogram

2.3 Investigation used accelerograms

Since, for non-linear dynamic analysis, the use of records of earthquake is required, therefore for this purpose, we have used records that are compatible with the conditions of the site, and geotechnical of Iran has different durability periods and maximum acceleration with good varieties, which below describes the specifications of earthquake [5].

2.3.1 Bam earthquake

This earthquake occurred on 12.26.2003. The earthquake's epicenter is located elevation 1094 meters above sea level in the geographic location 29° north and 58.33° east. The used records of this earthquake were about 13,310 data, and the time interval of this recorded data is about 0.02 seconds. The maximum acceleration values have been recorded for the L component is 0.64 g and for the T component is 0.528 g.

2.3.2 Tabas earthquake

The earthquake occurred on Saturday, September 16, 1978. Duration of the earthquake was 25 seconds. The earthquake records are for the longitudinal component (N16W), and the maximum acceleration is 0.917 g (915.3 cm/s²). The number of recorded data for this earthquake was 1639 data, and the time interval each of these data is 0.02 seconds.

2.3.3 Naghan earthquake

This earthquake occurred on April 5, 1977; the recorded data is for the longitudinal component of seismic. Maximum acceleration for this earthquake was recorded 0.712g (709.46 cm/s²); the number of recorded data for this earthquake was 4195 data in a time interval about 0.005 seconds.

2.3.4 Mexicosity earthquake

Records for this earthquake have about 2245 data by the time interval about 0.01 seconds, and a maximum value acceleration of this earthquake is presented 0.621 g.

2.3.5 Northridge earthquake

The earthquake occurred on 17/ 01/1994. Records for the earthquake have 2000 data, which are the time interval of the data 0.02 seconds; the maximum acceleration for this earthquake is recorded 0.8525 g.

In the analyze of models, all these accelerograms is used. In order to analysis the results for different seismicity zones of Iran, we modify accelerograms with the appropriate correction coefficient in accordance with the content presented in the previous section. Then we proceed to analyze the models with respect to the corrected accelerograms.

2.4 Distribution of earthquakes on buildings and Building materials

Before describing the distribution of earthquakes, a division briefly explains the different parts of a building with Building materials. Building materials are included ceiling and two walls perpendicular to each other, whose walls of located in the direction perpendicular to the earthquake, called the transverse walls (Walls B1 and B2 in Figure 2) and the walls are located together with an earthquake are called shear walls or vertical walls [6] (Walls A1 and A2 in Figure 1).

Inertia forces the motion of the earth, when the earthquake comes to building mass, the building, and the building materials, the mass is located in the ceiling and walls and causes the inertia force to the ceiling and walls. The mechanism for distributing the force, the roof, depending on the hardness and transverse shear walls, is transferred to the walls; the share of incoming shear walls directly is transmitted to the foundation, but since transverse walls rely on the ceiling, walls, and shear, inertia force contribution ceiling, wall, and transverse inertia force enters shear walls. Finally, by shear walls, it is transmitted to the foundation. With regard to the cases mentioned above, we conclude that, in building materials, shear walls have an important role in the field of inertial forces transmitted to the foundation. In fact, shear walls are the main ingredient in buildings, the building materials, the lateral forces, and destroying them lead to a reversal of the structure [1].

It should be noted, the mechanism of lateral force distribution in buildings with masonry, when that is done, the roof must have the necessary integrity, and be able to withstand and transmit their forces, and against the other components.

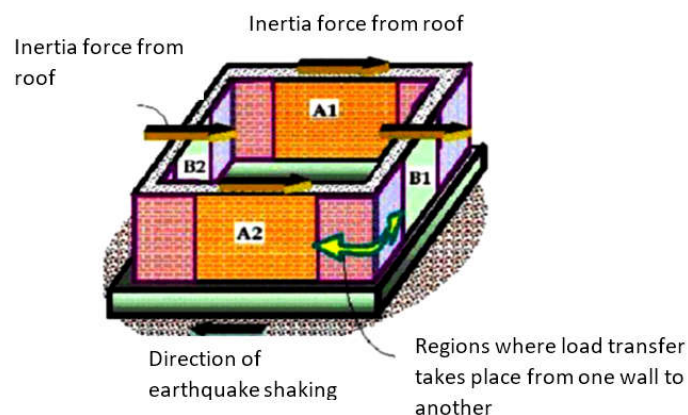

Figure 1. Different walls, with a different function in the buildings, the building materials [5]

2.5 Fracture mechanism

Once, the building will be exposed to seismic inertia force proportional to mass. Structure shall be imposed on the structure. During the movement, the vertical and horizontal directions, inertia forces entered the structure to be changed at any moment, and the result is a three-dimensional vibration of the building. Structural components that before the quake suffered substantially vertical loads, must be able to endure horizontal bars, which are imported to construct the bending moment and shear force extras. Observe the behavior of buildings; Building materials, when they are affected by the earthquake, show that vibrations in buildings heavily depends on how the walls connect to each other, as well as their inhibitors, the floor, and ceiling level [1].

In the old masonry buildings, where the wooden beams of the roof not inhibit the materials (or coils are locked together), the walls tend to separate from their connections. Vertical cracks in the corner of the walls had to be bent out of the page or occurred near the ends of the wall. The tensile strength of the wall is not enough to counter the inertia forces exerted in this circumstance; vibrating walls are not uniform; and exterior walls have to collapse Figure 2(B). When curb in place or coils of yarn-reinforced concrete are fastened to each other, the floor and ceiling levels of vibration walls occur simultaneously, Figure 2(C). However, the deflection out of the walls is associated with reduced resistance.

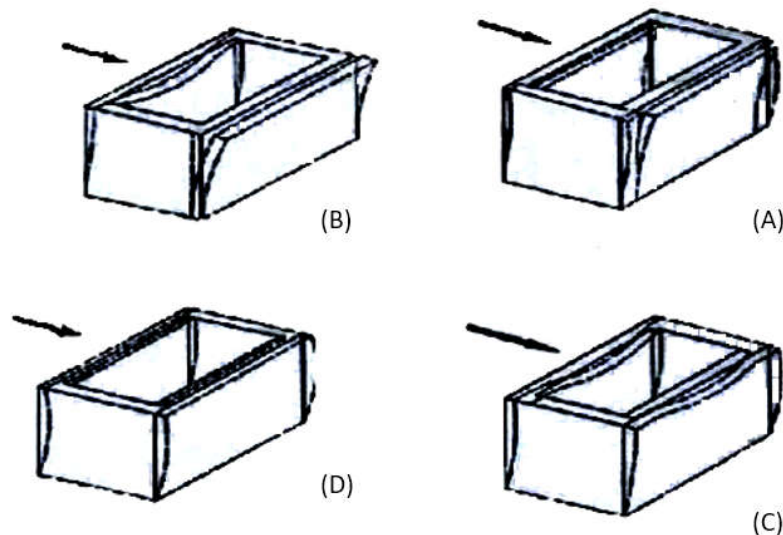

Figure 2. Vibration in buildings with masonry, gestures during an earthquake: A and B - structural walls, are not close to each other, c - structural walls, have been closed to each other, the coil, D - structural walls with solid concrete slab, have been closed to each other, the ceiling [1,7,8]

Obviously, walls reinforced concrete slabs by rigid and hank are connected together at the roof level, to represent better the behavior Figure 2(D). In this case, the vibration of the walls, at the same time, place, and out-of-plane bending of walls, is less important. The walls on all four sides are attached to the rigid support, and treated will leave. Nevertheless, the building behaves like a box, and the walls will help build resistance against lateral loads [2].

2.6 Fracture mechanisms brick walls

According to the analysis on the types of damages, the following conclusions regarding the broken mechanisms of masonry walls as a structural element can be summarized: A - A wall that is not connected to anything on the outside of the screen is not stable (Figure 3 (A)). It usually is against the wall by its own weight to resist the inertia

forces. Flexural strength of the wall, so less of it, in order to prevent the crumble out of the wall, after the horizontal tensile cracks which occur in the lower part of the wall, unless it is armed, the vertical.

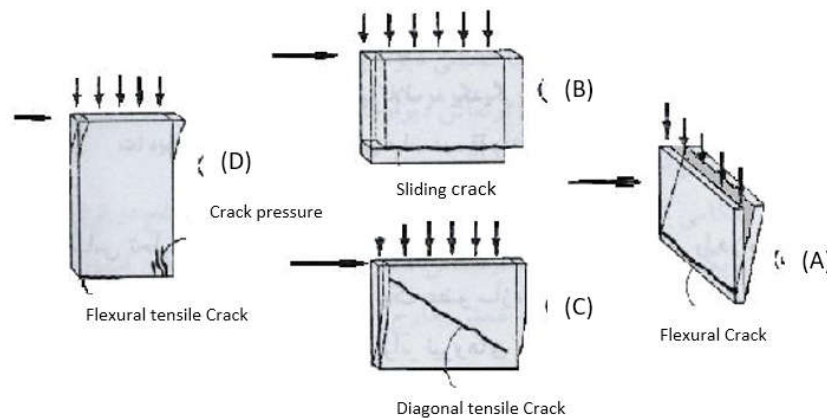

Figure 3. Mechanisms of broken in wall-free structures [1, 5, 9]

- When a wall is affected by the forces within a page, it becomes a shear wall, and its strength is greater. In many cases, there is a break of such a wall, which is related to its geometry (length to height ratio) and material properties. States below are some broke modes governed at the wall:

- Horizontal sliding or break in pure shear, when that happens, horizontal crack along mortar increases, the brick wall (Figure 3(B)).
- Diagonal tension, the breakdown section, when that happens, the diagonal cracks started to be along the mortar, and spread it on the wall (Figure 3(C)).
- Flexural break, which occurs when the occurrence of horizontal tensile cracks in the tensile zone cross-sectional area of the reduced pressure, and the break occurs in the compression zone (Figure 3(D)). However, the broken mechanism can be included various combinations of the modes described above [10].

3. Results and Discussion

3.1 Analyzing damage indexes

Damage indexes are classified into two main groups based on reflection and strength. Damage indexes based on the resistance depend on properties of structural elements such as area section of beams, columns, and walls and general properties of material. At first, these indexes were employed by Shiga *et al.* [1], in 1968 and then were employed by Y. Yang and L. Yang [2]. The damage indexes based on reflection need to be analyzed and also have greater accuracy. These indexes depend on parameters such as plastic deformation, Hysteresis energy, stiffness, number of cycles with specified plastic domain, etc. [1]. As examples of these indexes, it can be pointed to Park & Ang index, which is a cumulative index that effect of deformation and energy is considered together [2]. Also, it can be pointed to Krawinkler & Zohrei indexes [1] which is an index based on cumulative deformation and Ghobara index [5] which can consider the effect of hardness before and after the earthquake. However, a large number of presented parameters are considered as a topical index and identify just amount of damage of the structural elements. Therefore, these indexes must adjustment by using other indexes that are known to the general criteria for the deterioration of structural in order to determine the overall damage of structure. Therefore, we can

mention Bracci *et al.* index [2] and Park & Ang index [6], which are topical index normalized by using absorbed energy in it.

3.2 Park & Ang index

One of the indexes of vulnerability that has an extensive usage is the vulnerability indexes of Park & Ang (1985), which is formed by a linear combination of energy absorption and normalized deformation [1]:

$$D = \frac{\delta_m}{\delta_u} + \beta_e \frac{\int dE}{F_y \cdot \delta_u} \quad (11)$$

Where β_e is a strength reduction-based coefficient on energy, F_y is yields load, δ_m is the observed maximum displacement, δ_u is displacement corresponding to failure mode, and $\int dE$ is absorbed energy by the member.

The first term is a criterion of the static displacement and does not consider the cumulative damage. The second term is a criterion of the absorbed energy and includes the cumulative damage. The advantage of this model is simply based on the fact that grading is consistent with the observed damage. Park and Ang proposed that $D=0.4$ must be boundary between serviceability and non-serviceability states, but in 1987, they gave more details as follow [5]:

$0.1 > D$ no damage: Few small cracks

$0.25 > D \geq 0.1$ low damage: Small cracks in the member

$0.4 > D \geq 0.25$ average damage: Severe and gaps cracks

$1.0 > D \geq 0.4$ vigorous damage: explode of concrete and appearance of steel

$1.0 \leq D$ collapse

This model had been used in the first version of program of *IDARC*, but in the next one (1992), this relationship was changed a little, and the displacement moment the curvature had been used:

$$D = \frac{\phi_m - \phi_y}{\phi_u - \phi_y} + \beta_e \frac{\int dE}{M_y \cdot \phi_u} \quad (12)$$

The problem, which is in Park and Ang model, is related to calculating of β_e . Thereafter, others had been introduced β_e as probability with 0.27 median and standard deviation of 0.6 as a random variable. In *IDARC* program, the amount of $\beta_e = 1$ had been proposed, which must not exceed more than 0.5 in normal conditions. However, the damage index is solely the index that researchers have accentuated. On the accuracy of its performance in various failures, Stone and Taylor suggested values on the basis of the tests on 82 samples for D . Williams and colleagues also proposed the similar values for the D index at experiments with predominant effect of cutting those proposed values shows very good performance in the range of average damages.

These proposed values are mentioned at Table 1 [2].

Table 1. Various standards of damages

	The minimum amount of damage index		
	Park & Ang	Eston & Tailor	Viliyamz
Repairable	0.1	0.11	0.12
unrepairable	0.4	0.4	0.39
Collapse	1	0.77	0.28

3.3 Assessment of walls Seismic vulnerability and damage index

With respect to matters given in the source of 14, Park and Ang Damage index is solely index for which different researchers have confirmed accuracy of its performance in various failure. Therefore, this damage index is identified as a criterion comparison.

Park and Ang put Damage Index $D = 0.4$ as the criterion of serviceability or non-serviceability, indeed if $D < 0.4$, it is serviceable and it is not suitable for more than that and structures have been completely broken down for $D > 1$. If the index number was not near to 1.0, in fact, the wall was only minor damage. In this research, IDARC 2D finite element software was used for nonlinear dynamic analysis and modeling of walls.

In Figures 4 to 7, damage index values are given, from the analysis of walls, for mentioned accelerograms refined for different zones of Iran seismicity. Also, they have been compared with damage index of Park & Ang and have been investigated damage rate of walls.

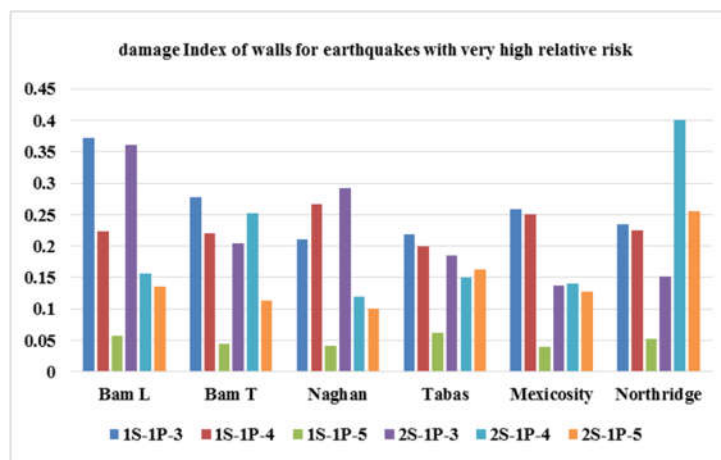

Figure 4. Comparison of the damage index of walls for earthquakes with very high relative risk

Walls 1S-1P-3 and 1S-1P-4 have repairable damage for all earthquake accelerometers, but changing the opening length to five meters causes the damage level to change to a low damage level for all accelerometers.

The floor increase has caused Wall 2S-1P-4 to reach an unreparable level of damage for the Nathan accelerometer.

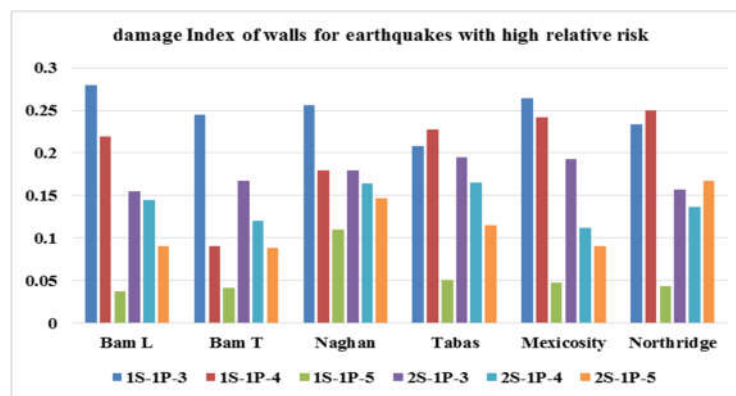

Figure 5. Comparison of the damage index of walls for earthquakes with high relative risk

1s-1p-5 wall have low damage for all earthquakes. The 2s-1p-5 wall for Bam and Mexicity earthquakes contain low damage and for other earthquakes repairable. Other walls for all earthquakes or for often them contain repairable damages.

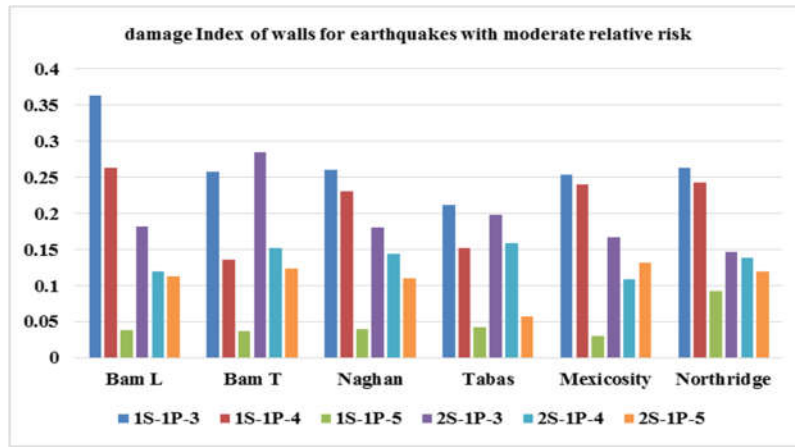

Figure 6. Comparison of the damage index of walls for earthquakes with a moderate relative risk

Other walls in most of the earthquakes have repairable damages, or we can say that it is repairable for most of the earthquakes.

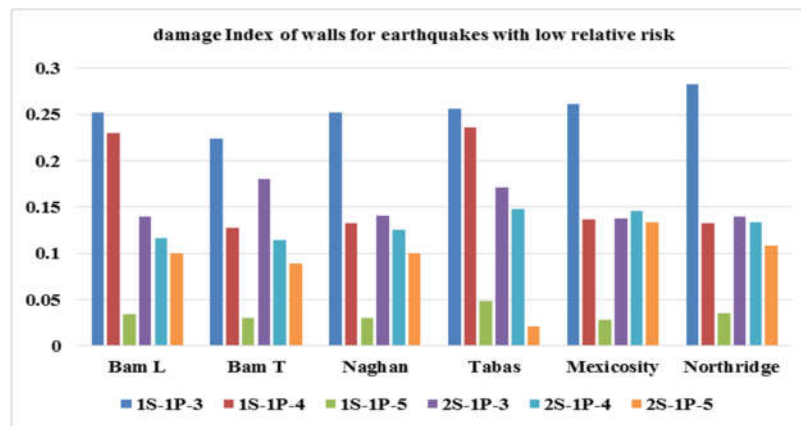

Figure 7. Comparison of the damage index of walls for earthquakes with low relative risk

1S-1P-5 and 2S-1P-5 walls for all of the earthquakes, including low damages. Other walls in most of the earthquakes have little damages and for some of them have repairable damages.

4. Conclusion

According to the results of the analysis of the walls for the accelerometers compatible with the site conditions and the comparison of the obtained data with the values of the regulations, the following results have been obtained. The results show that for all seismic zones in the regulations, increasing the span length has reduced the total percentage of the relative displacement of the roof, which improves the performance level of the walls. Increasing the number of floors for the walls led to an increase in the total percentage of relative displacement of the roof for

all modified earthquakes with different seismic zones in Iran, and the performance level of the wall decreased. The results show that for the seismic zone with moderate and low relative risk, none of the walls have reached the collapse limit and are practically functional. Walls 1S-2P-3, 1S-2P-4, and 1S-1P-5 have immediate occupancy performance level for all existing seismic zones and actually have the best performance. The investigation of the walls failure index shows that: Wall 2S-1P-4 for very high relative risk and high relative risk have an unreparable level of damage. The comparison of data shows that by reducing the maximum acceleration of earthquakes for different seismic zones, the damage to the walls decreases so that for the medium and low seismic zones, none of the walls reach the limit of irreparable damage. Moreover, it is added to the number of walls that have minor damage. Comparative morphological studies (TM & GM) revealed the deformation grid and wireframe with more details. In the deformation grid, there are differences between the two populations due to folds and twists. Wireframe shows differences better in certain places, such as the head, caudal peduncle, and middle area of the body. In general, the geometric results are more accurate and better than Traditional morphometric. I hope that the drought problem will be solved in the future so that we can study more populations for phenotypic adaptation.

Conflicts of Interest

The authors declare no conflict of interest associated with this manuscript.

References

1. Aminifar E, Akhondi F, Lourenço PB. Verification of mechanical properties of historical brick masonry walls with masonry quality index method in Iran. *Int. J. Architect Herit.*, 2023, 12:2001-2011.
2. Asteris PG, Chronopoulos M, Chrysostomou C, Varum H, Plevris V, Kyriakides N, Silva V. Seismic vulnerability assessment of historical masonry structural systems. *Eng. Struct.*, 2014, 62:118-134.
3. Betti M, Galano L, Vignoli A. Comparative analysis on the seismic behaviour of unreinforced masonry buildings with flexible diaphragms. *Eng. Struct.*, 2014, 61:195-208.
4. Cattari S, Calderoni B, Calìo I, Camata G, de Miranda S, Magenes G, Milani G, Saetta A. Nonlinear modeling of the seismic response of masonry structures: Critical review and open issues towards engineering practice. *Bull. Earthquake Eng.*, 2022, 20:1939-1997.
5. Alemi F. Experimental study of seismic behaviour of typical Iranian masonry brick walls. *The 14th World Conference on Earthquake Engineering*, 2008, Beijing, China.
6. Hendry AW, Sinha BP, Davies S. Design of masonry structures. 2017, Boca Raton: CRC Press.
7. D'Altri AM, Sarhosis V, Milani G, Rots J, Cattari S, Lagomarsino S, Sacco E, Tralli A, Castellazzi G, de Miranda S. Modeling strategies for the computational analysis of unreinforced masonry structures: Review and classification. *Arch. Comput. Meth. Eng.*, 2020, 27:1153-1185.
8. Gkournelos P, Triantafyllou T, Bournas D. Seismic upgrading of existing masonry structures: A state-of-the-art review. *Soil Dynam. Earthquake Eng.*, 2022, 161:107428.
9. Bosiljkov V, Page A, Bokan-Bosiljkov V, Žarnić R. Evaluation of the seismic performance of brick masonry walls: Structural Control and Health Monitoring. *Struct. Control Health Monit.*, 2010, 17:100-118.
10. Zade NP, Sarkar P, Davis PR. Seismic behaviour of unreinforced masonry. In: Recent Trends in Wave Mechanics and Vibrations: Select Proceedings of WMVC 2018. 2020, Berlin: Springer, pp 151-164.

How to cite this article: Khaksefidi S, Rahdar HA. Investigating the Effect of Changing the Span Length and the Number of Floors on the Seismic Parameters of the Confined Masonry Wall. *Curr. Appl. Sci.*, 2025, 3(1):29-40. <https://doi.org/10.22034/cas.2024.434139.1036>
